

FUTRUS® HALO BUMPER RAIL

CORIAN® SURFACE MOUNTED BUMPER RAILS

FUTRUS®
SOLUTIONS WITH CORIAN® DESIGN

designed with

CORIAN®
SOLID SURFACE

MODEL FHBUMPER

Specification Sheet





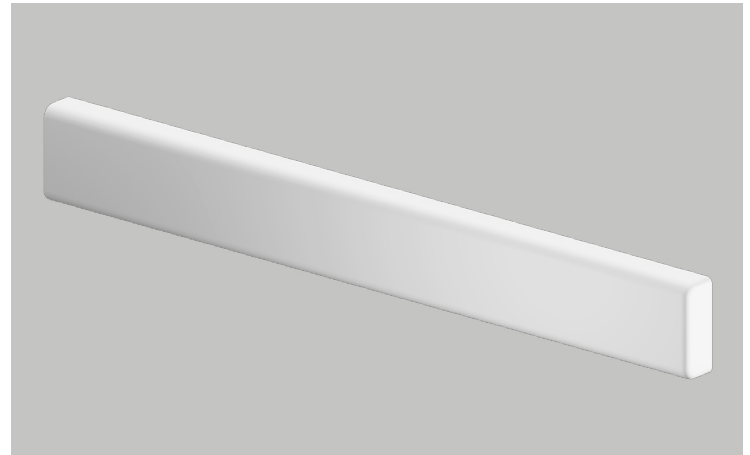

FEATURES

- Made with Corian®
- Impact resistance
- Bleach cleanable, seamless & nonporous
- Resists scratching, staining & chipping
- GREENGUARD® Certified to resist mold, virus & bacteria growth
- Simple Installation



• Halo Bumper Rail

STANDARD CORIAN® COLOR OPTIONS

Color*	Code	Description
	00	Glacier White
	01	Cameo White
	02	Bisque
	03	Bone
	04	Silver Gray
	05	Vanilla

Color tiles are for reference only*
See full Corian® color choices at [Futrus.com](https://www.futrus.com)

CERTIFICATIONS

- NSF/ANSI Standard 51 certified
- GREENGUARD certified to resist the growth of viruses, bacteria & mold
- GREENGUARD Gold low VOC emissions
- Contributes to LEED certification credits
- Class 1 (Class A) fire rated

FUTRUS® HALO BUMPER RAIL

CORIAN® SURFACE MOUNTED BUMPER RAILS

FUTRUS
SOLUTIONS WITH CORIAN® DESIGN

designed with

CORIAN
SOLID SURFACE

MODEL FHBUMPER

Specification Sheet

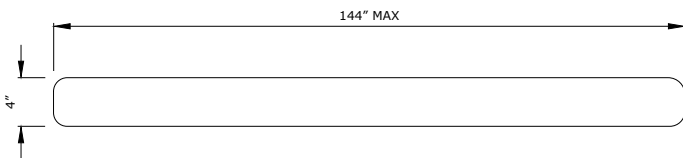

Elevation

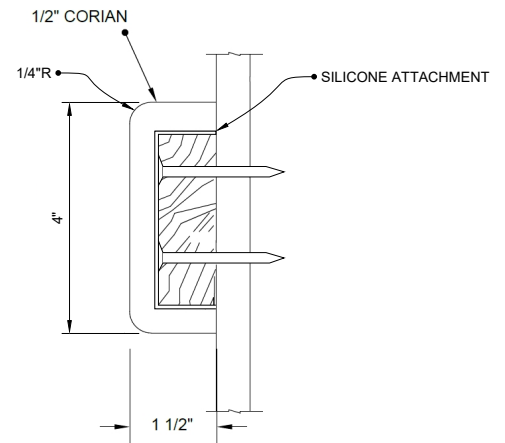

Section

STANDARD SIZES

Dimensions (Inches)

Code	Width (X)	Depth	Height
FHBUMPER_X	1" - 144"	1-1/2"	4"
CUSTOM			

RECOMMENDED SPECIFICATION

The Futrus Bumper Rail, Model FHBUMPER. Bumper rail to be made of 100% acrylic Corian® solid surface with no polyester blends. Bumper rail to be NSF/ANSI Standard 51 certified; GREENGUARD certified to resist the growth of viruses, bacteria & mold; GREENGUARD Gold low VOC emissions; Contribute to LEED certification credits; Class 1 (Class A) fire rated.

TECHNICAL INFORMATION

- All dimensions are nominal
- Futrus® 1-year limited warranty
- Corian® 10-year material warranty

EXAMPLE MODEL SPECIFICATION

FHBUMPER_120_GLACIERWHITE
(Model_Width_Corian Color)