

FUTRUS® ASCEND NURSE STATION

MODULAR NURSE STATION DESIGNED FOR MAXIMUM HYGIENE, ADAPTABILITY AND DURABILITY



designed with



MODEL FASCEND_N

Specification Sheet

Division 12 Furnishings

FEATURES

- Made with Corian® solid surface
- Bleach cleanable, seamless & nonporous
- Resists scratching, staining & chipping
- Adaptable height & length
- Self-supporting patented construction
- Impact resistant
- GREENGUARD® certified to resist mold & bacteria growth
- Technology integration
- Range of functional & aesthetic options
- Quick & easy installation
- Available in all Corian® colors
- Choice of thermofoil colors



SCREEN OPTIONS

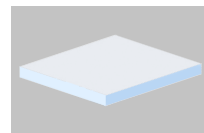

Glass | GL

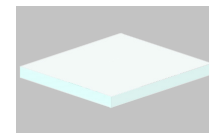

Plexiglass | PG

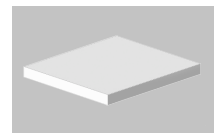

Architectural Resin | AR

STANDARD CORIAN® COLOR OPTIONS

Color*	Code	Description
	GW	Glacier White
	CW	Cameo White
	BI	Bisque
	BN	Bone
	VY	Silver Gray
	NL	Vanilla

OPTIONAL UPGRADES

Code	Description
WC	Wireless charging
PG	Power grommet*
FA	Floor anchors**

Standard is heavy duty furniture glides**

STANDARD CORIAN® COLOR OPTIONS

Color*	Code	Description
	LW / TW	Laminate / Thermofoil Walnut
	LC / TC	Laminate / Thermofoil Cherry
	LM / TM	Laminate / Thermofoil Maple

Color tiles are for reference only*
See full Corian® color choices at Futrus.com

CERTIFICATIONS

- NSF/ANSI Standard 51 certified
- GREENGUARD certified to resist the growth of viruses, bacteria & mold
- GREENGUARD Gold low VOC emissions
- Contributes to LEED certification credits
- Class 1 (Class A) fire rated

FUTRUS® ASCEND NURSE STATION

MODULAR NURSE STATION DESIGNED FOR MAXIMUM HYGIENE, ADAPTABILITY AND DURABILITY



designed with



MODEL FASCEND_N_L

Specification Sheet

Division 12 Furnishings

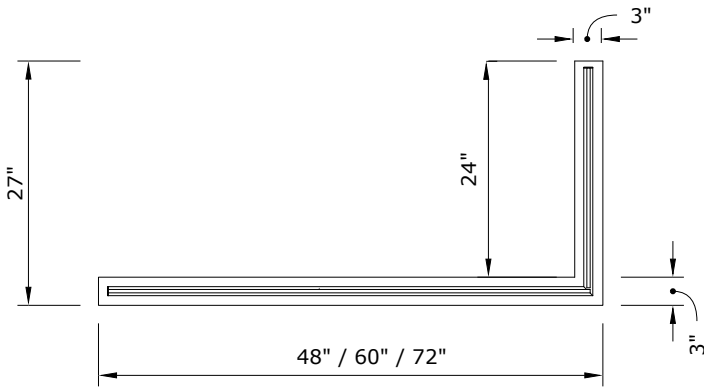

Plan View

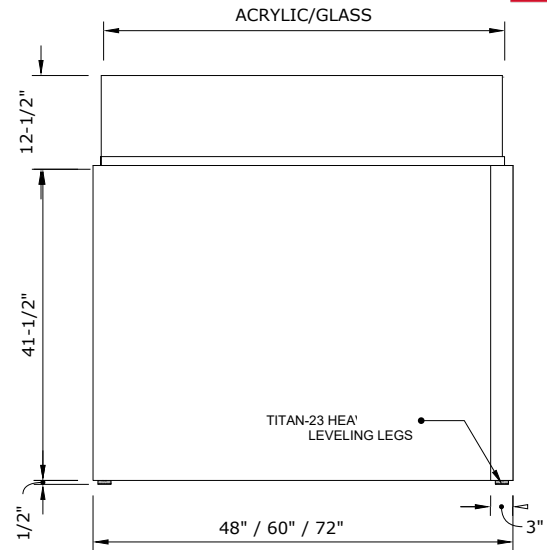

Elevation View

STANDARD SIZES

Dimensions (Inches)

Code	Width	Depth	Height	Screen Height	Wall Depth
FASCEND_N_L_48_30_42_12.5	48"	27"	42"	12-1/2"	3"
FASCEND_N_L_60_30_42_12.5	60"	27"	42"	12-1/2"	3"
FASCEND_N_L_72_30_42_12.5	72"	27"	42"	12-1/2"	3"
CUSTOM					

INTEGRATIONS

- Futrus Ascend Wall System
- Futrus Countertops
- Futrus® Arkz Desk
- Futrus Casework Systems
- Futrus Adaptz Tables

TECHNICAL INFORMATION

- All dimensions are nominal
- Futrus® 1-year limited warranty
- Corian® 10-year material warranty

EXAMPLE MODEL SPECIFICATION

FASCEND_N_L_48_27_42_12.5_3_GW_FA
 (Model_Width_Depth_Height_Screen Height_Wall Depth_Corian Color_Optional Extra)

RECOMMENDED SPECIFICATION

To be specified in Division 12 Furnishings. The Futrus Ascend Nurse Station, Model FASCEND_N_L. Partition surfaces to be made of 100% acrylic Corian® solid surface with no polyester blends. Desk to be NSF/ANSI Standard 51 certified; GREENGUARD certified to resist the growth of viruses, bacteria & mold; GREENGUARD Gold low VOC emissions; Contribute to LEED certification credits; Class 1 (Class A) fire rated.

FUTRUS® ASCEND NURSE STATION

MODULAR NURSE STATION DESIGNED FOR MAXIMUM HYGIENE, ADAPTABILITY AND DURABILITY



designed with



MODEL FASCEND_N_R

Specification Sheet Division
12 Furnishings

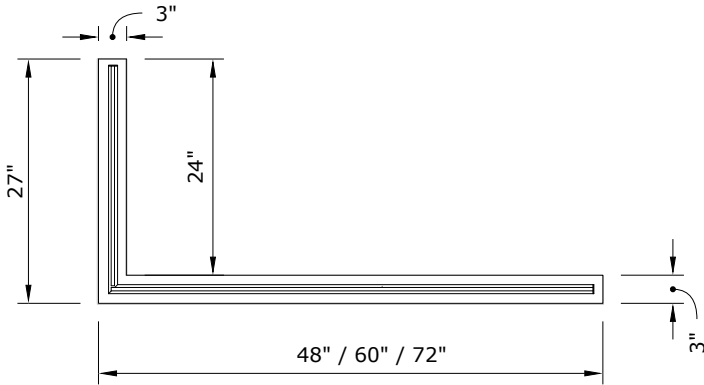

Plan View

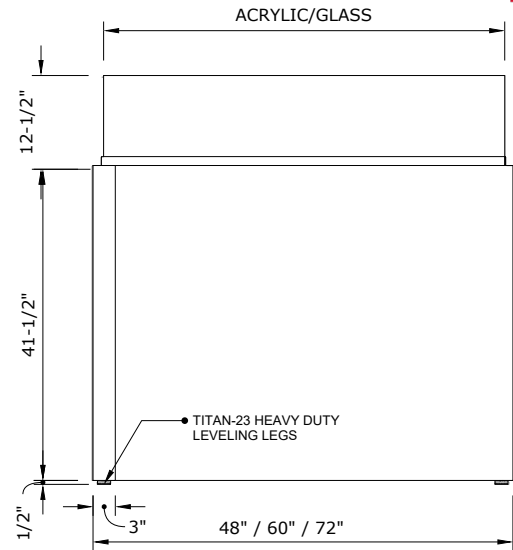

Elevation View

STANDARD SIZES

Dimensions (Inches)

Code	Width	Depth	Height	Screen Height	Wall Depth
FASCEND_N_R_48_27_42_12.5	48"	27"	42"	12-1/2"	3"
FASCEND_N_R_60_27_42_12.5	60"	27"	42"	12-1/2"	3"
FASCEND_N_R_72_27_42_12.5	72"	27"	42"	12-1/2"	3"
CUSTOM					

INTEGRATIONS

- Futrus Ascend Wall System
- Futrus Countertops
- Futrus® Arkz Desk
- Futrus Casework Systems
- Futrus Adaptz Tables

TECHNICAL INFORMATION

- All dimensions are nominal
- Futrus® 1-year limited warranty
- Corian® 10-year material warranty

EXAMPLE MODEL SPECIFICATION

FASCEND_N_R_48_27_42_12.5_3_GW_FA
(Model_Width_Depth_Height_Screen Height_Wall Depth_Corian Color_Optional Extra)

RECOMMENDED SPECIFICATION

To be specified in Division 12 Furnishings. The Futrus Ascend Nurse Station, Model FASCEND_N_R. Partition surfaces to be made of 100% acrylic Corian® solid surface with no polyester blends. Desk to be NSF/ANSI Standard 51 certified; GREENGUARD certified to resist the growth of viruses, bacteria & mold; GREENGUARD Gold low VOC emissions; Contribute to LEED certification credits; Class 1 (Class A) fire rated.

FUTRUS® ASCEND NURSE STATION

MODULAR NURSE STATION DESIGNED FOR MAXIMUM HYGIENE, ADAPTABILITY AND DURABILITY



designed with



MODEL FASCEND_N_U

Specification Sheet

Division 12 Furnishings

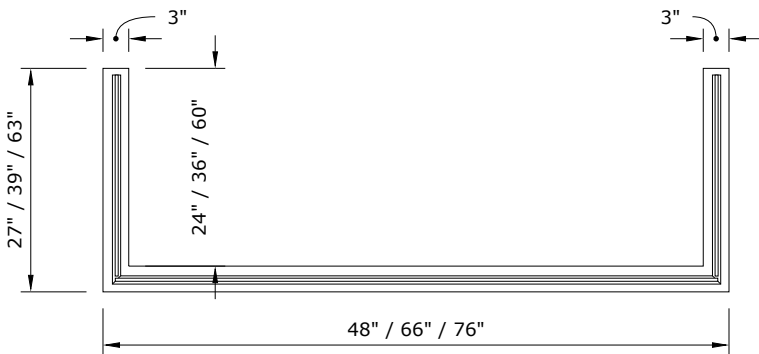

Plan View

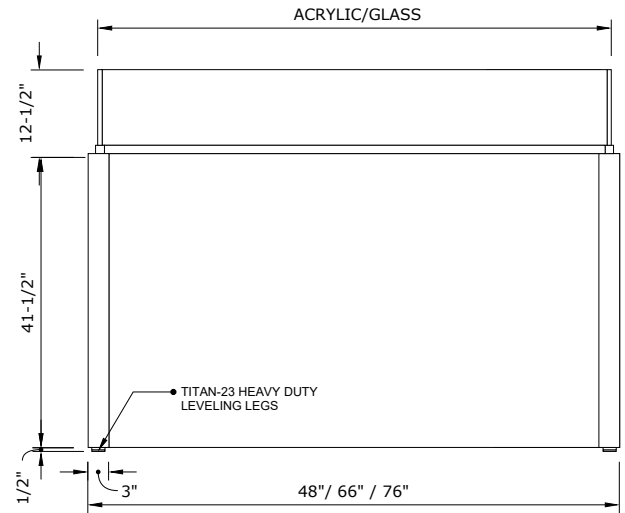

Elevation View

STANDARD SIZES

Dimensions (Inches)

Code	Width	Depth	Height	Screen Height	Wall Depth
FASCEND_N_U_48_27_42_12.5_3	48"	27"	42"	12-1/2"	3"
FASCEND_N_U_60_27_42_12.5_3	66"	27"	42"	12-1/2"	3"
FASCEND_N_U_72_27_42_12.5_3	76"	27"	42"	12-1/2"	3"
FASCEND_N_U_48_39_42_12.5_3	48"	39"	42"	12-1/2"	3"
FASCEND_N_U_60_39_42_12.5_3	66"	39"	42"	12-1/2"	3"
FASCEND_N_U_72_39_42_12.5_3	76"	39"	42"	12-1/2"	3"
FASCEND_N_U_48_63_42_12.5_3	48"	63"	42"	12-1/2"	3"
FASCEND_N_U_60_63_42_12.5_3	66"	63"	42"	12-1/2"	3"
FASCEND_N_U_72_63_42_12.5_3	76"	63"	42"	12-1/2"	3"
CUSTOM					

TECHNICAL INFORMATION

- All dimensions are nominal
- Futrus® 1-year limited warranty
- Corian® 10-year material warranty

INTEGRATIONS

- Futrus Ascend Wall System
- Futrus Countertops
- Futrus® Arkz Desk
- Futrus Casework Systems
- Futrus Adaptz Tables

RECOMMENDED SPECIFICATION

To be specified in Division 12 Furnishings. The Futrus Ascend Nurse Station, Model FASCEND_N_U. Partition surfaces to be made of 100% acrylic Corian® solid surface with no polyester blends. Desk to be NSF/ANSI Standard 51 certified; GREENGUARD certified to resist the growth of viruses, bacteria & mold; GREENGUARD Gold low VOC emissions; Contribute to LEED certification credits; Class 1 (Class A) fire rated.

EXAMPLE MODEL SPECIFICATION

FASCEND_N_U_76_39_42_12.5_3_GW_FA
 (Model_Width_Depth_Height_Screen Height_Wall Depth_Corian Color_Optional Extra)