

# FUTRUS® HYBRID ELIPZ TABLE

## ELONGATED OVAL SHAPED OCCASIONAL TABLE WITH SOLID SURFACE TOP & LAMINATE OR THERMOFOIL COMPONENTS

### MODEL FELIP\_H

Specification Sheet

Division 12 Furnishings

#### FEATURES

- Corian® solid surface tabletop
- Bleach cleanable
- Seamless & nonporous
- Resists scratching, staining, chipping & impacts
- Impact resistant
- SpotGuard sanding finish
- Standard & adaptable sizes
- Technology integration
- Suitable for indoor & outdoor use
- Corian® is GREENGUARD® certified to resist mold & bacteria growth
- Available in all Corian® solid surface colors
- Available in a range of laminate & thermofoil colors
- Vertical or horizontal grain



#### STANDARD CORIAN® COLOR OPTIONS

Color*	Code	Description
	GW	Glacier White
	CW	Cameo White
	BI	Bisque
	BN	Bone
	VY	Silver Gray
	NL	Vanilla

#### OPTIONAL UPGRADES

Code	Description
PG	Power/USB grommet
CS	Charging Surface
FA	Floor Anchor
WB	Weighted Base

#### STANDARD LAMINATE COLOR OPTIONS

Color*	Code	Description
	LW / TW	Laminate Walnut / Thermofoil Walnut
	LC / TC	Laminate Cherry / Thermofoil Cherry
	LM / TM	Laminate Maple / Thermofoil Maple
	LA1 / T1	Laminate White / Thermofoil White
	LA2 / T2	Laminate Black / Thermofoil Black

Color tiles are for reference only\*  
See full Corian® color choices at [futrus.com](http://futrus.com)

#### CERTIFICATIONS

- GREENGUARD certified to resist the growth of viruses, bacteria & mold
- GREENGUARD Gold low VOC emissions
- Contributes to LEED certification credits
- Class 1 (Class A) fire rated



# FUTRUS® HYBRID ELIPZ TABLE

## ELONGATED OVAL SHAPED OCCASIONAL TABLE WITH SOLID SURFACE TOP & LAMINATE OR THERMOFOIL COMPONENTS

### MODEL FELIP\_H

Specification Sheet

Division 12 Furnishings

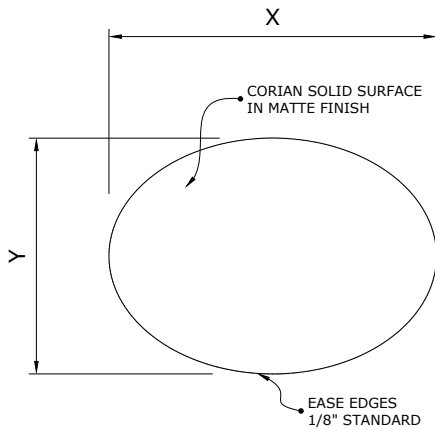

Plan View

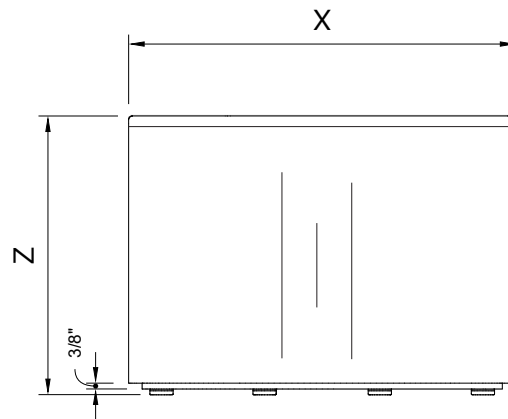

Front Elevation

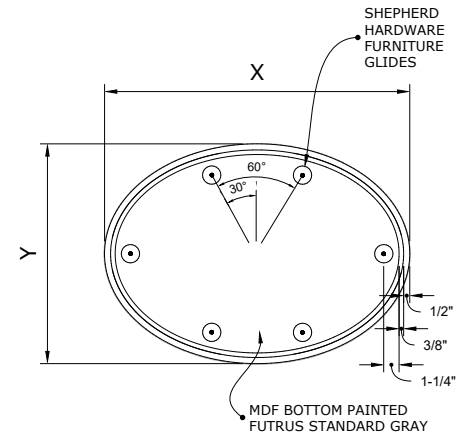

Bottom View

### STANDARD SIZES

#### Dimensions (Inches)

Code	Length (X)	Width (Y)	Height (Z)
FELIP_H_302218	30"	22"	18"
FELIP_H_361818	36"	18"	18"
FELIP_H_402418	40"	24"	18"
FELIP_H_482418	48"	24"	18"
FELIP_H_602418	60"	24"	18"
CUSTOM			

### RECOMMENDED SPECIFICATION

The Futrus Hybrid Elipz Table, Model FELIP\_H. Hybrid Elipz table to be made of solid surface with laminate or thermofoil components. Table to be NSF/ANSI Standard 51 certified; GREENGUARD certified to resist the growth of viruses, bacteria & mold; GREENGUARD Gold low VOC emissions; Contribute to LEED certification credits; Class 1 (Class A) fire rated.

### TECHNICAL INFORMATION

- All dimensions are nominal
- Futrus® 5-year limited warranty
- Corian® 10-year material warranty

### EXAMPLE MODEL SPECIFICATION

FELIP\_H\_401818\_CS\_GW

(Model\_Length|Width|Height\_Optional Upgrade\_Corian Color\_3D Texture)



futrus.com  
info@futrus.com

1.877.388.FUTRUS1 [388.7871]